

please use this for Nicolai Bikes

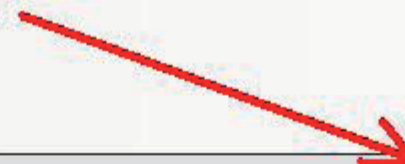

CRANKSET FRAME CLEARANCE INFORMATION										
Chain Ring Combination	L1	L2	L3	L4	W1	W2	W3	W4	W4	W4
26/39	31 mm	55 mm	81 mm	190 mm (175 mm crank arm length)	43.5 mm	44.5 mm	52.5 mm	65.7 mm	69.5 mm	W4
28/42		60 mm	87 mm							70.5 mm
30/45		64 mm	93 mm							
<b>Q-factor</b>								Q156	Q164	Q166
<b>Bottom Bracket Type(s)</b>								GXP BB30 PressFit™ 30	BB30 PressFit 30	GXP PressFit 30

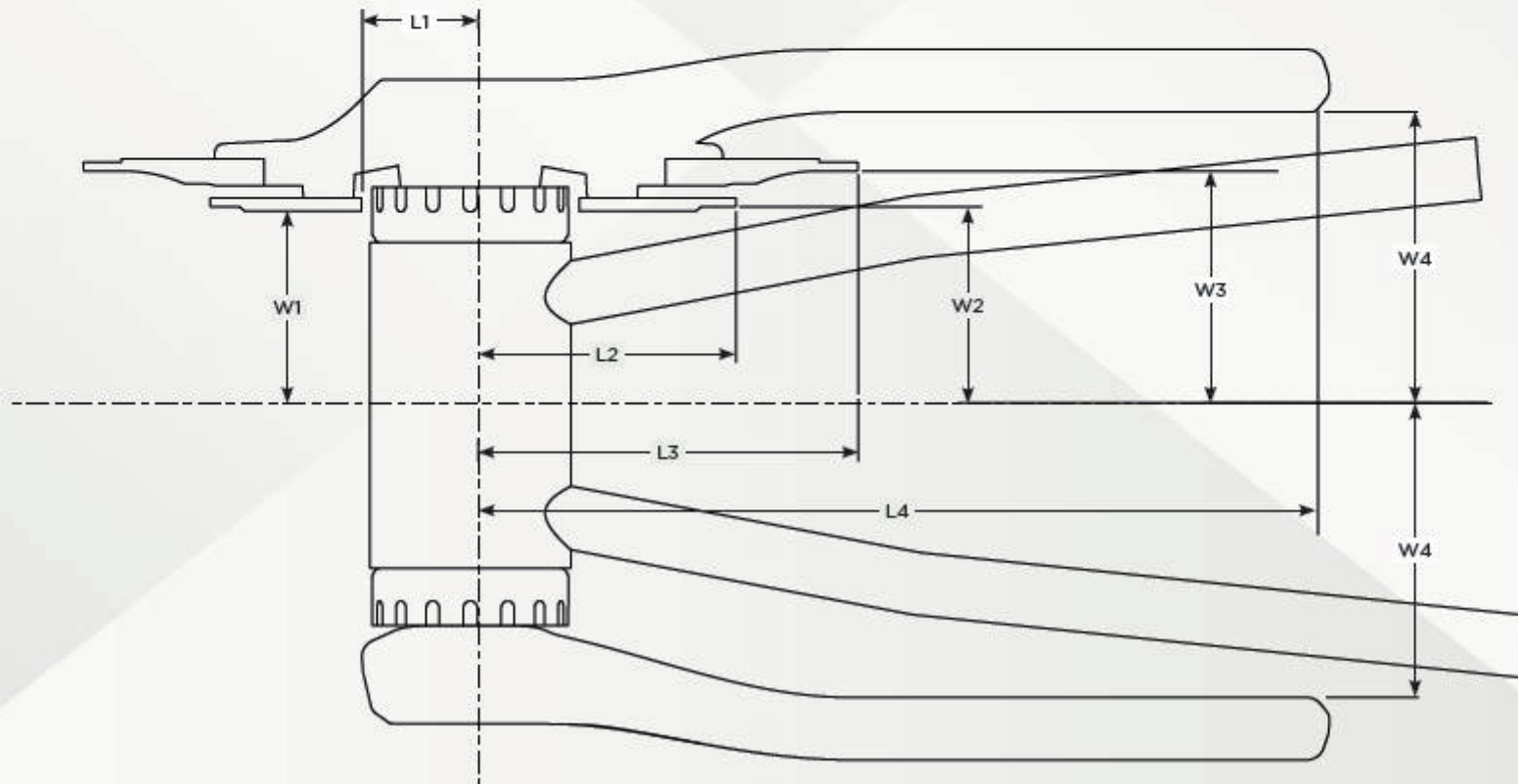

# XX™ Front Derailleur - Low & High Clamp

		CLAMP/BODY POSITION*				TIRE CLEARANCE		
		Chain Ring	A	B	C	D	E	F
<b>LOW CLAMP</b>	39T	61 mm	76 mm	-		100 mm	40 mm	33 mm
	42T	67 mm	82 mm			106 mm		
	45T	73 mm	88 mm			112 mm		
<b>HIGH CLAMP</b>	39T	114 mm	129 mm	79 mm	-		Top Pull = 25 mm Bottom Pull = 32 mm	34 mm
	42T	120 mm	135 mm	85 mm				
	45T	126 mm	141 mm	91 mm				

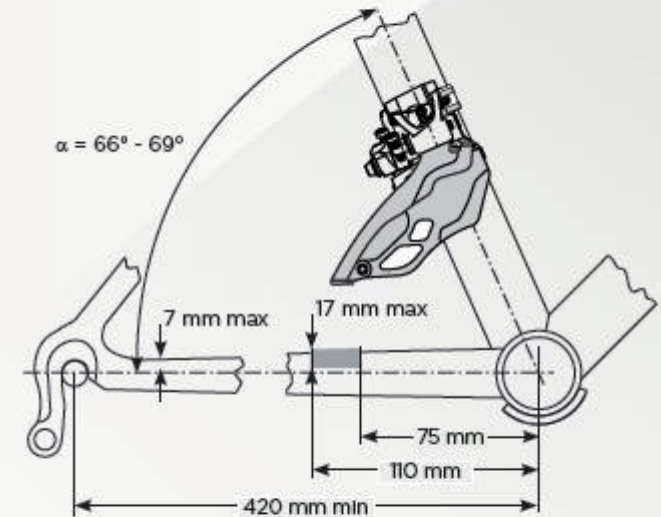

\* Be sure to leave adequate clearance between bottle cage mounts and front derailleur clamp.

FRONT DERAILLEUR FRAME COMPATIBILITY AND CAPACITY INFORMATION							
	Clamp Diameter	Rear Capacity	Index	Cable Routing	Chain Stay Angle ( $\alpha$ )	Chain Line	Material
<b>LOW CLAMP</b>	31.8 mm (use adaptor) 34.9 mm 38.2 mm	10 speed	Yes	Top Pull or Bottom Pull	66° - 69°	49.5 mm	Clamp - Forged Aluminum Cage - Steel
<b>HIGH CLAMP</b>	31.8 mm 34.9 mm 38.2 mm						